

Proiettore LED ECO

10W

7206/N

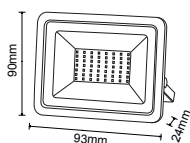

30W

7208/N

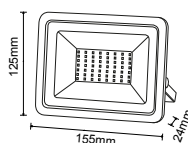

50W

7209/N

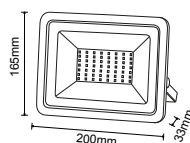

100W

7210/N

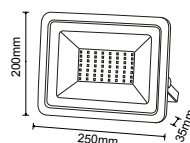

200W

7220/N

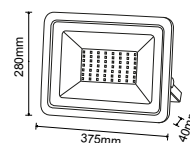
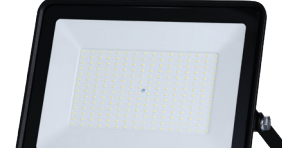

System Valve

L'apparecchio monta una valvola di respirazione impermeabile antideflagrante per la fuoriuscita della condensa

Caratteristiche:

Cavo: VDE in dotazione, 3.0x0.75 mm² da 30 cm di lunghezza.

Diffusore: vetro temperato resistente agli shock termici e agli urti.

Verniciatura: a polvere, resistente alla corrosione ed alle nebbie saline, stabilizzato ai raggi UV.

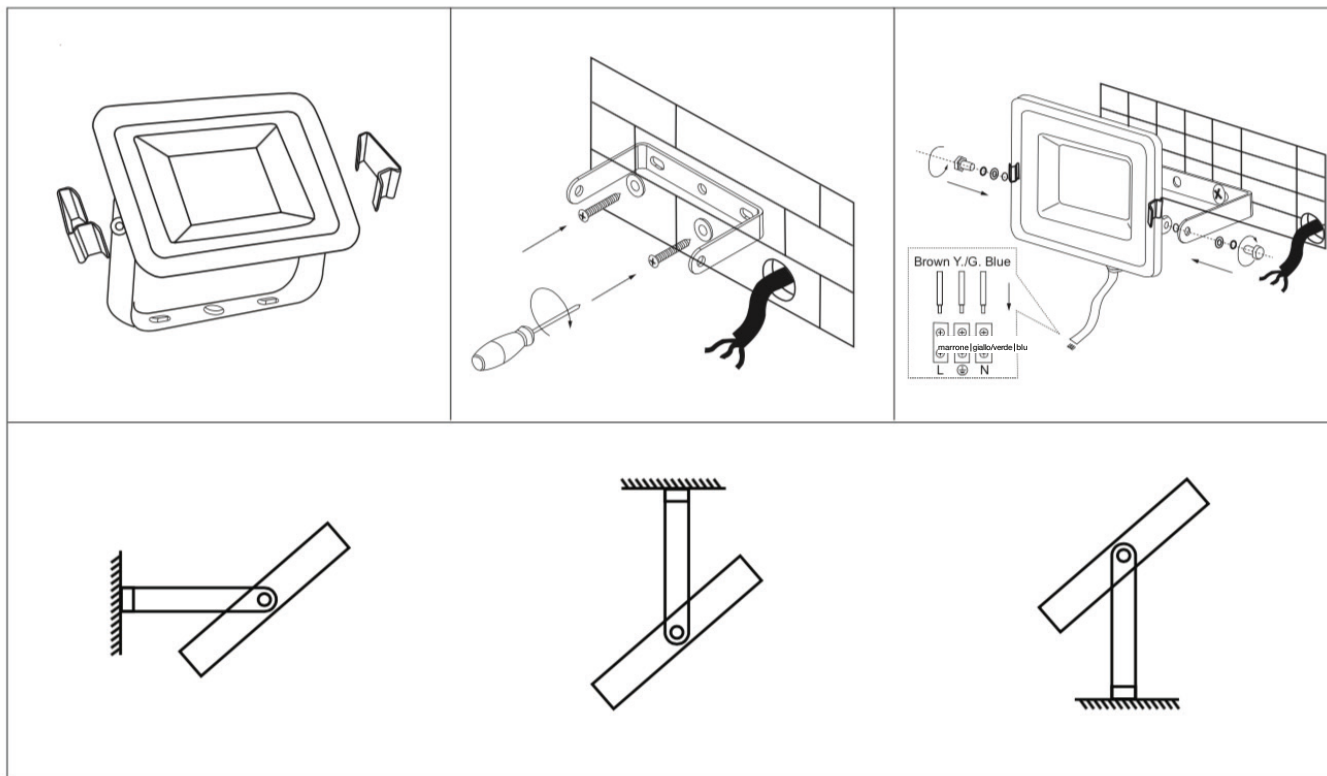

	7206/N	7208/N	7209/N	7210/N	7220/N
Wattaggio	10W	30W	50W	100W	200W
Lumen	1000	3000	5000	10000	20000
Kelvin	4000K				
Range Voltaggio/Frequenza	AC200-265V / 50-60Hz				
Angolo	120°				
grado IP	65				
CRI	Ra>80				
Autonomia	50.000 ore				
Classe protezione shock elettrico	Classe I				
Colore	Nero				
Materiali	alluminio pressofuso, vetro temperato				